

### First Floor Plan

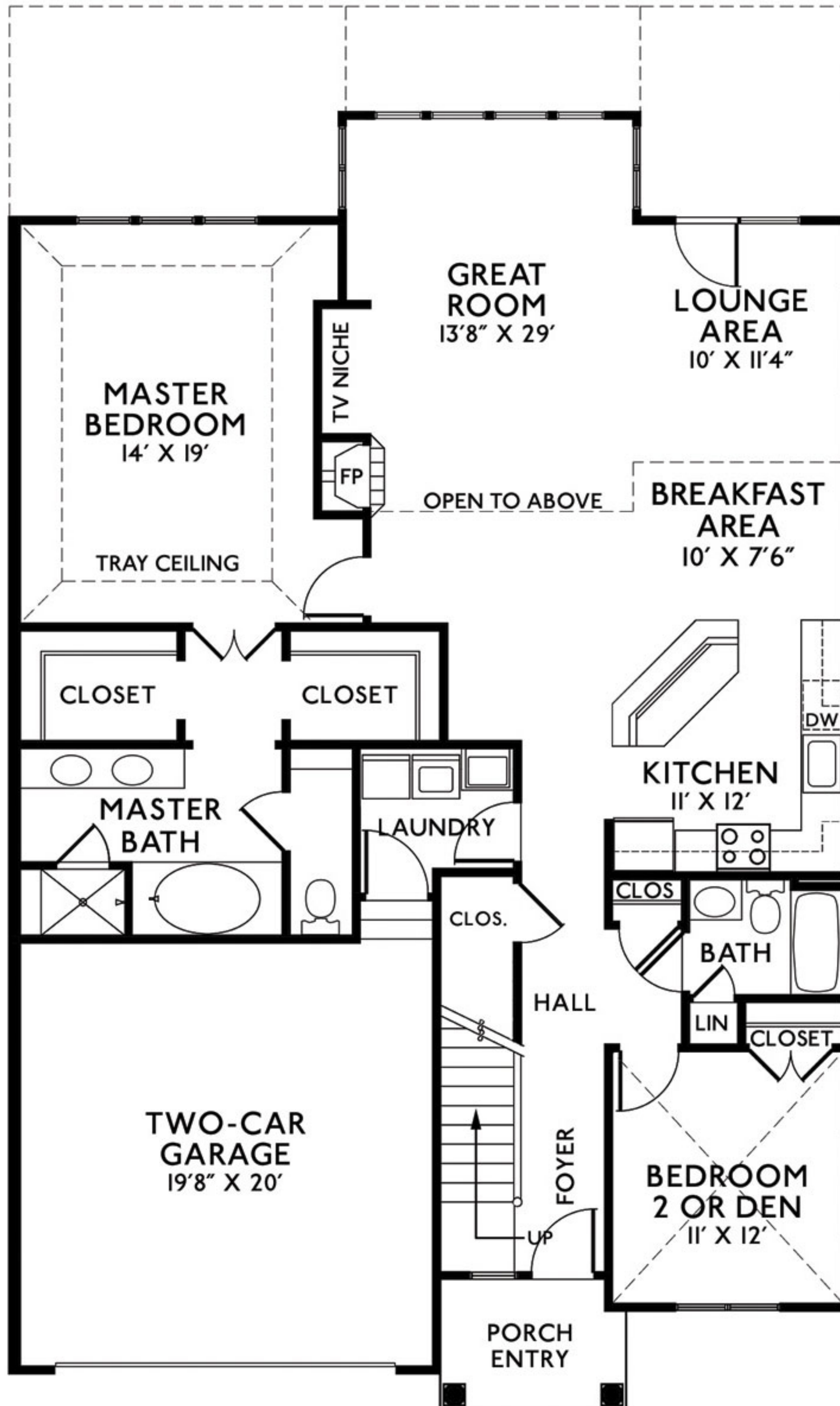

1,780 sq. ft. on first floor



## Optioned Second Floor Plan

Optional Second Floor with  
2 Bedrooms, 2 Baths, & Loft/Media Room

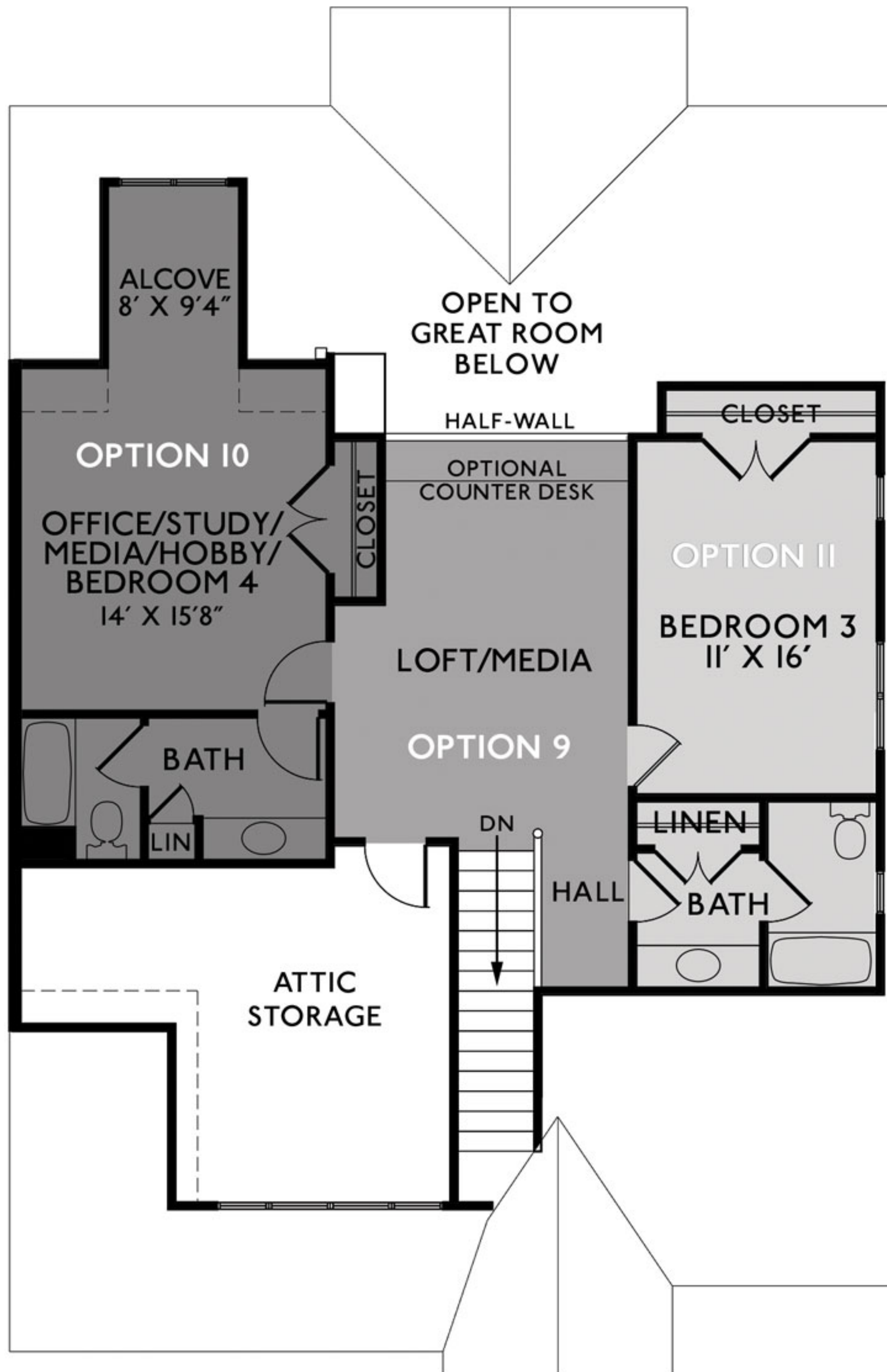

Optional Plans

Optional Dining Rooms

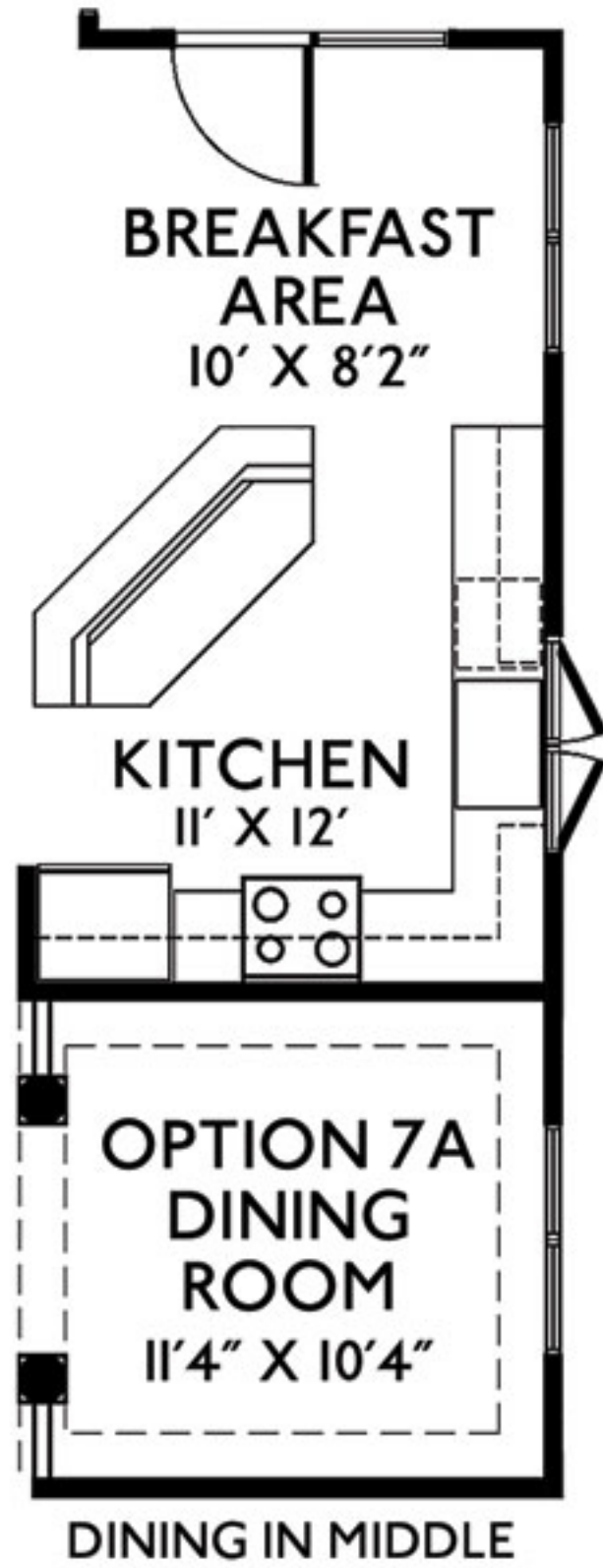

Optional Back Porches and Rooms

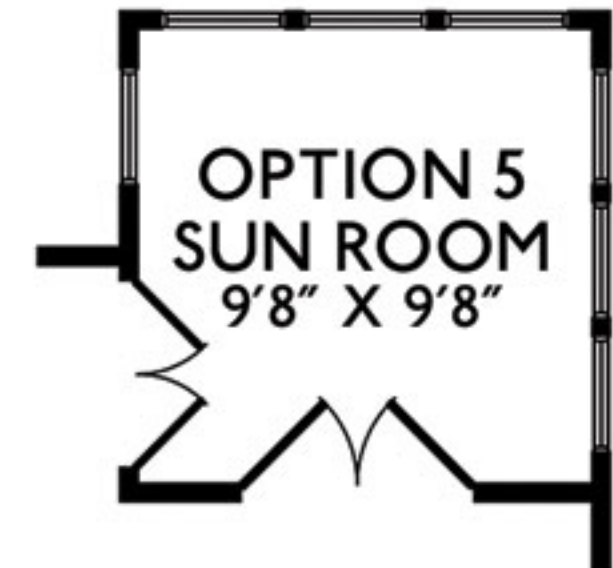
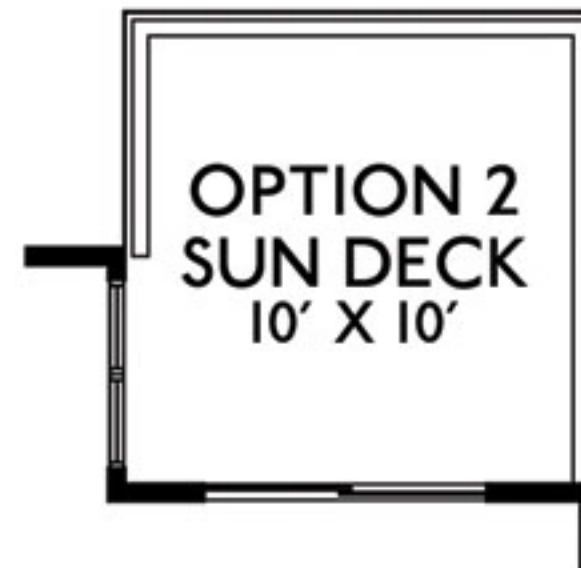
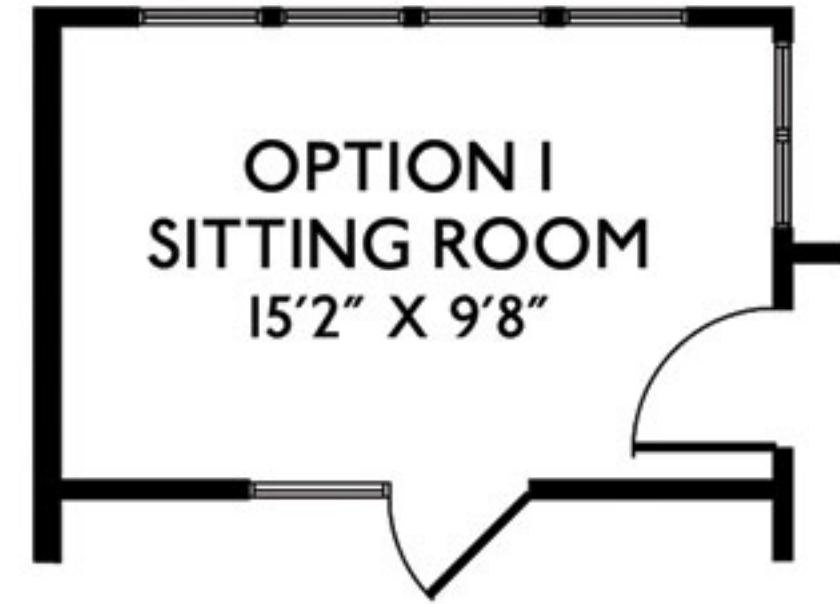

Optional Bay Windows



Optional Front Den

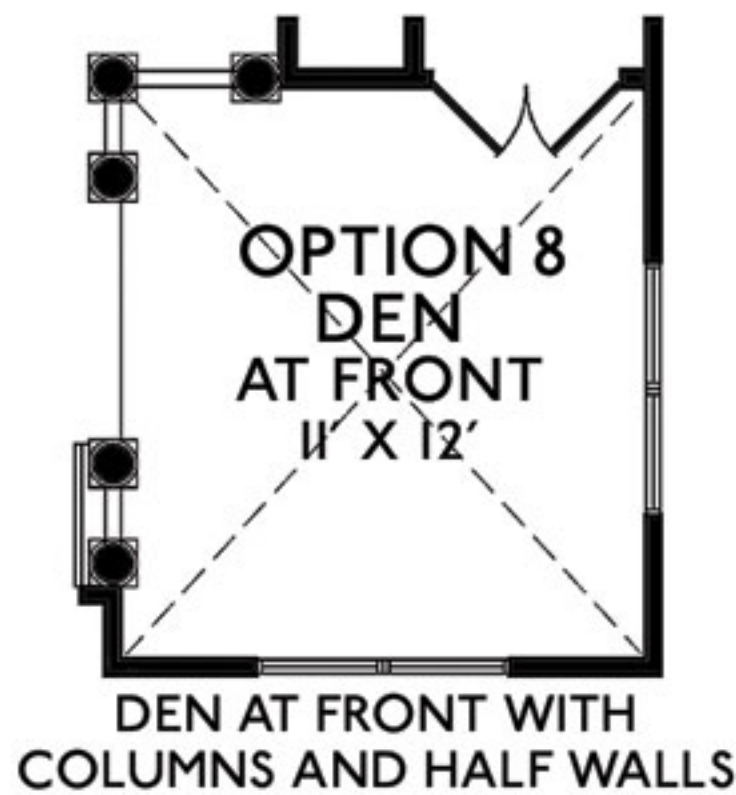

Optional Front Porch

